

FEATURES

- *Stainless steel interior and exterior with galvanised back panel*
- *Gas: R404A for Freezers*
- *Insulation Foam: C5H10,ODP, Zero emissions*
- *43°C ambient working temperature*
- *Come with wired mid shelf*
- *Castors as standard*
- *All European parts, Aspera compressor, EBM fan motor*
- *Fan Force Cooling*
- *Auto Defrost Function*
- *Carel or Dixell digital controller*
- *Allow 100 mm clearance for air ventilation, all vent must left clear*

YPF9025



YPF9035



YPF9045



INFORMATION	YPF9025	YPF9035	YPF9045
Capacity	220L	300L	390L
Power	400W	450W	550W
Voltage	240V/50Hz	240V/50Hz	240V/50Hz
Working Temp	-22°C~-17°C	-22°C~-17°C	-22°C~-17°C
Ambient Temp	43°C	43°C	43°C
Dimensions(mm)	W1200 x D600 x H838,71kg	W1500 x D600 x H838,74kg	W1800 x D600 x H838,81kg
Packaging Dimensions(mm)	W1254 x D654 x H867,86kg	W1554 x D654 x H867,100kg	W1854 x D654 x H867,111kg



+



2 YEARS WARRANTY ON ALL PARTS & LABOUR
* EXTRA 2 YEARS WARRANTY ON PARTS WHEN YOU REGISTER WITH US ONLINE

YPF9025

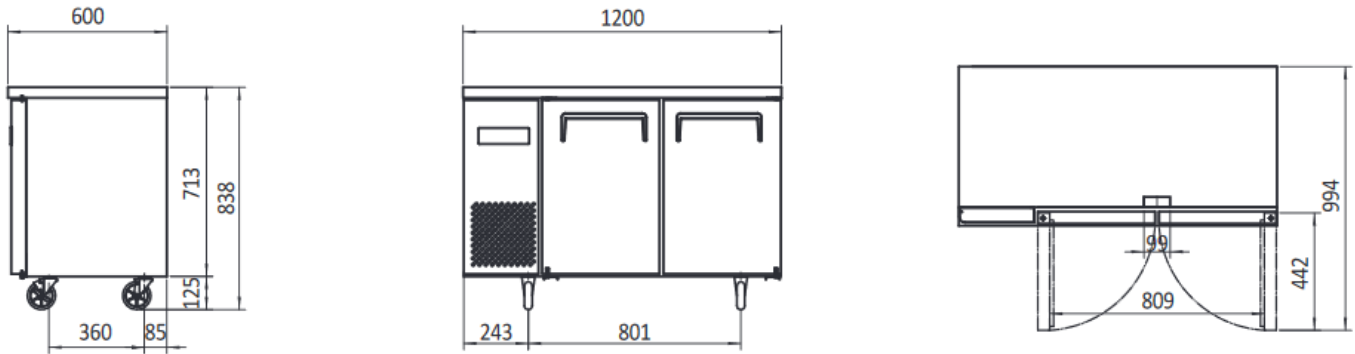

YPF9035

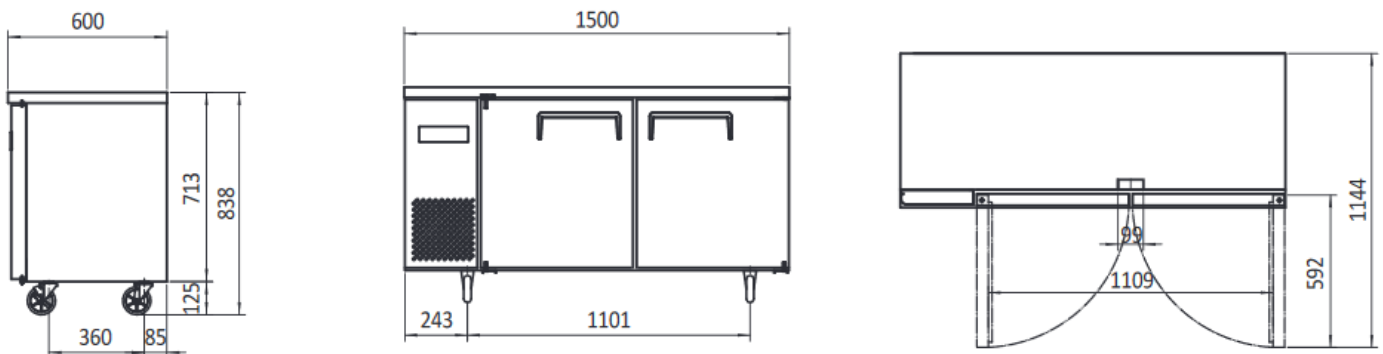

YPF9045

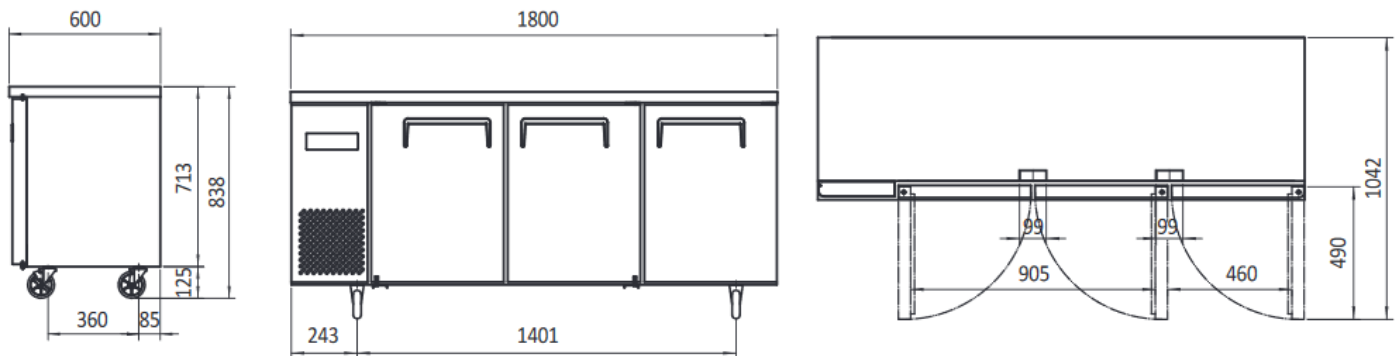

2 YEARS WARRANTY ON ALL PARTS & LABOUR
* EXTRA 2 YEARS WARRANTY ON PARTS WHEN YOU REGISTER WITH US ONLINE