

## BACK BAR SERIES: SBB-3G

### FEATURES / BENEFITS

#### •EQUIPPED WITH EASY-TO-CLEAN AIR FILTER

The accumulation of dust in the condenser causes failures and/or breakdowns in refrigeration. Refrigeration operate normally until they accumulate a certain amount of dust. When they reach over their limit, performance will drop rapidly, resulting in damages and possible disposal of stored goods. This is why all refrigeration manufacturers require the condenser to be cleaned at least once a month for warranty to remain. Fortunately for SKIPIO, this process is simplified due to the frontal access air filter device. Users only need to pull out the filter and vacuum lightly to remove the dust. Simply place it back into position when complete.

#### •EFFICIENT REFRIGERATION SYSTEM

SKIPIO's refrigerators are designed with oversized and balanced (CFC Free R-134A) refrigeration systems. These include efficient evaporators and condensers for faster cooling and greater efficiency.

#### •FORCED AIR COOLING SYSTEM

Fast cooling and balanced temperature throughout the cabinet.

#### •STAINLESS STEEL COUNTERTOP AND INTERIOR

The exterior of cabinet is constructed with heavy gauge reinforced stainless steel countertop and wear-resistant black vinyl coated galvanized steel. Interior is stainless steel except galvanized steel top. SKIPIO Back Bar model guarantees utmost in cleanliness and long product life. It also can add a touch of style to the most refined setting.

#### •ERGONOMICALLY DESIGNED DOORS

Customers' fatigue fades away with easy grip handles and doors that open effortlessly. These features along with self-closing doors make this the ultimate choice in customer convenience.

#### •LED LIGHTING INTERIOR

#### •DOUBLE PANE GLASS DOORS WITH LOW-E GLASS

#### (SG MODELS)

#### •HIGH-DENSITY POLYURETHANE INSULATION

The entire cabinet structure is foamed-in-place using high density, CFC free polyurethane insulation.

#### •ADJUSTABLE, HEAVY DUTY, PE(POLYETHYLENE)

#### COATED WIRE SHELVES

#### •SIDE MOUNT COMPRESSOR UNIT

#### •REFRIGERATOR HOLDS 33°F ~38°F FOR THE BEST IN BEVERAGE PRESERVATION



Model	Doors	Capacity (Liters)	Shelves	Compressor (HP)	Amps (A)	Net Weight (Kg)	L X D X H (mm)
SBB-3G	3	605	4	1/4	3.1	139	2040x590x1011

## BACK BAR SERIES: SBB-3G

### Model: SBB-3G

SPEC SHEET	SBB-3G
Classification	Refrigerator
Cabinet Dimension (WxDxH mm)	2040x590x1011
Capacity (Liters)	605
Inner Temperature	1°C~8°C
Doors	3
Number of Shelves	4
Refrigerant	R-134a
Compressor (Hp)	1/4
Lamp	Light panel / LED lamp
Cooling Type	Fan cooling type
Insulation Type	Polyurethane / Cyclopentane + CFC Free
Temperature Control Type	Digital
Amps (A)	3.1
Voltage (V/Hz/Ph)	240V 50Hz 1Ph
Power (W)	409
Weight (Kg)	139

### PLAN VIEW (unit: mm)

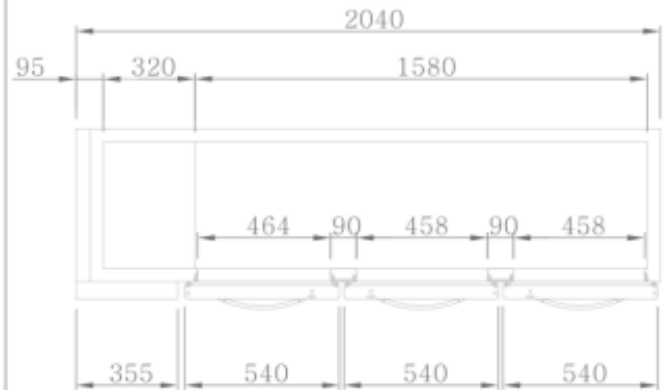

### TOP VIEW

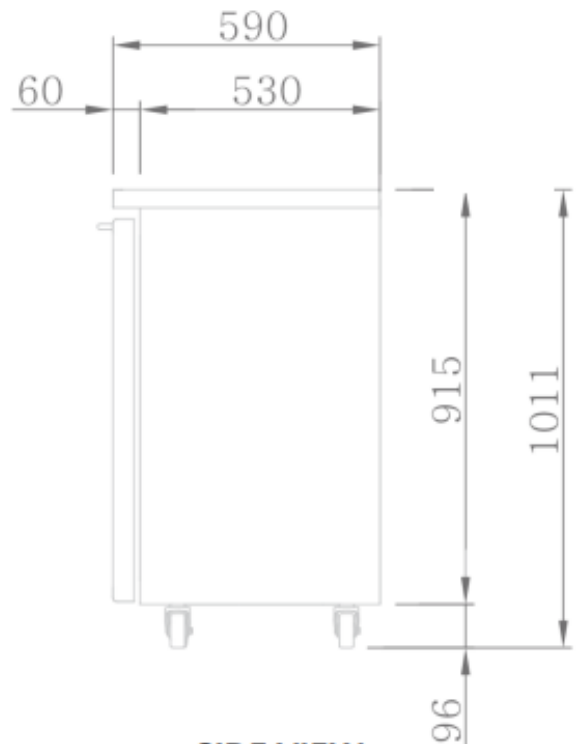

### SIDE VIEW

**WARRANTY 2 YEARS**  
PARTS & LABOUR

