

# SHAMROCK



by

**Austwide**  
sales and rentals pty ltd

## AFD SERIES:- GLASS DOOR FREEZERS



AFD420



AFD930

### FEATURES:

- Operating Temperature  $-18^{\circ}$  to  $-22^{\circ}\text{C}$  @ ambient temperature of  $32^{\circ}\text{C}$
- Only requires one standard power point (GPO):- 240V 50Hz 10 amp.
- Digital Temperature Display.
- Individual adjustable shelves per door maximizing display configurations.
- Recessed LED lighting to interior.
- Individual light switch to interior and signage.
- Triple glazed thermal insulated heated glass doors.
- Aluminium Framed doors with locks.
- Positive seal torsion bar self closing doors for low maintenance.
- Commercial castors, for ease of cabinet movement.
- Cyclic defrost with timed backup insures frost free refrigeration.
- Auto hot gas condensate removal requires no pumping.

### MAIN DATA

Specifications are subject to change without notice. E&OE.

Model	Doors	Volume (Net L)	Shelves	Dimensions (mm) Width x Depth x height	Voltage	Power Outlet	Cord Length	Shipping Weight
<b>AFD420</b>	1	412	4	680 x 720 x 2045	240v/50hz	10 amp	2.4	138kg
<b>AFD930</b>	2	920	8	1370 x 720 x 2045	240v/50hz	10 amp	2.4	227kg

Head Office: Unit 1/35 Rimfire Drive, Hallam, Vic 3803. Phone: 1800 813 987 Fax: 03 8786 3572  
Email: sales@austwiderentals.com websites: www.austwidesales.com.au or austwiderentals.com

# SHAMROCK



by

**Austwide**  
sales and rentals pty ltd

## AFD SERIES:- GLASS DOOR FREEZERS

### Specification

- **Shelves:** 4 height adjustable, PVC coated, shelves per door. 4 stainless steel shelf clips per shelf fit to stainless steel shelf posts.
- **Lighting:** LED 18watt 1200mm tubes recessed into the inner walls provide high visibility lighting, with low energy consumption.
- **Refrigeration System:** Fully balanced self contained condensing unit with forced draught evaporator and condenser.
- **Compressor:** AFD Series is equipped with [EMBRACO](#) compressors, the world leader in domestic and light commercial compressors.
- **Refrigerant:** R404A.
- **Defrost:** Cyclic defrost, with no-cost, hot gas condensate disposal. Supplemented with timed defrosts via electronic controller.
- **Electronic Controller:** Italian designed and Manufactured, Dixell temperature controller.
- **Evaporator:** Epoxy coated to mini-

mize the potential of corrosion and thus future gas leaks.

- **Operation conditions:** -18° to -22° C at up to 32° C ambient.
- **Electrical:** Units come ready for connection to 240volt 50hz 10amp GPO. It is recommended that a dedicated GPO be used.
- **Construction:** Corrosion resistant Pre-painted steel interior and exterior.
- **Insulation:** 50mm high density polyurethane foamed in place, Blowing agent, Cyclopentane for CFC free Ozone protection and superior insulating properties.
- **Door:** Heated Triple glazed thermal insulated toughened glass. Constructed with aluminium frame and fitted with locks.
- **Hinging:** Self closing torsion spring.
- **Gasket:** PVC welded one piece magnetic gasket, removable without the need for tools.
- **Castors:** 4 (2 x locking) x 75mm swivel commercial castors.
- **Model Features:** Digital Tempera-

ture readout.

**Warranty<sup>1</sup>:** Austwide's Manufacturer's warranty 12 month parts and labour. See terms and conditions of sale for full description.

### Optional Extras:

- Additional Shelves.
- Livery to sides and illuminated sign.

### Outstanding Benefits

- **Condensing unit:** Bottom mounted placing the unit in the coolest position, close to the floor, which puts less strain on the refrigeration system providing longer life and greater efficiency.
- **Optimal product placement:** The FD Series lifts the product up away from the floor. Placing it in the optimal position for your customers to easily reach in and retrieve product without the need for excessive stooping.
- **Matching refrigerator:** AGD Series refrigerators match the look of the AFD Freezer Series.

ELEVATIONS. (not to scale)

1.terms and conditions apply. Visit web site for full details. [www.austwidesales.com.au](http://www.austwidesales.com.au)  
Specifications are subject to change without notice. E&OE.

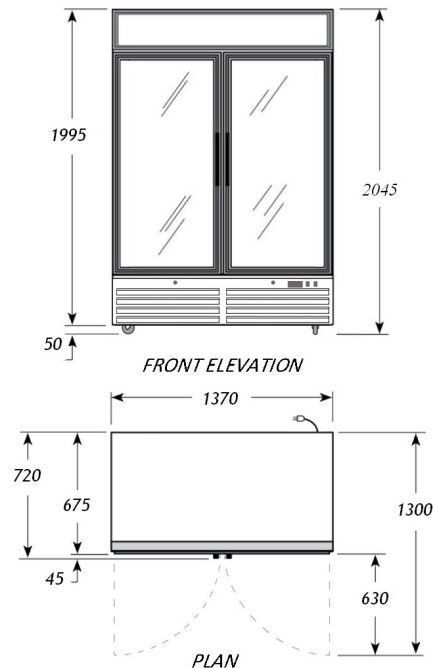
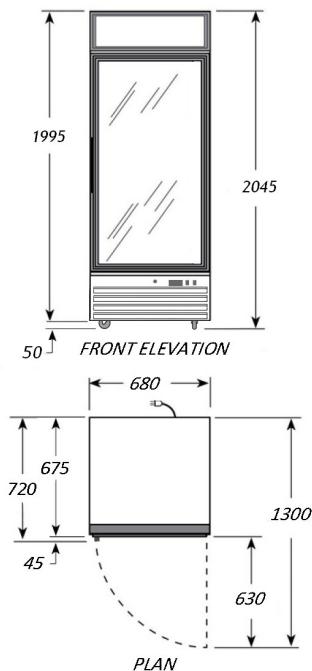

Head Office: Unit 1/35 Rimfire Drive, Hallam, Vic 3803. Phone: 1800 813 987 Fax: 03 8786 3572  
Email: [sales@austwiderentals.com](mailto:sales@austwiderentals.com) websites: [www.austwidesales.com.au](http://www.austwidesales.com.au) or [austwiderentals.com](http://austwiderentals.com)